

PT5-12

12Volt 5Ah

Specifications

Nominal Voltage(V) 12V

Nominal Capacity

20 hour rate	(0.25A to 10.50V)	5Ah
10 hour rate	(0.475A to 10.50V)	4.75Ah
5 hour rate	(0.85A to 10.20V)	4.25Ah
1 C	(5A to 9.60V)	3.17Ah
3 C	(15A to 9.60V)	2Ah

Weight Approx. 1.53kg(4.18Lbs.)

Internal Resistance (at 1KHz) Approx. 19 mΩ

Maximum Discharge Current for

5 seconds: 75A

Charging Methods at 25°C (77°F)

Cycle use:

Charging Voltage 14.4 to 15.0V

Coefficient -5.0mV/°C/cell

Maximum Charging Current : 1.5A

Standby use:

Float Charging Voltage 13.5 to 13.8V

Coefficient -3.0mV/°C/cell

Operating Temperature Range

Charge -15°C (5°F) to 40°C (104°F)

Discharge -15°C (5°F) to 50°C (122°F)

Storage -15°C (5°F) to 40°C (104°F)

Charge Retention (shelf life) at 20°C (68°F)

1 month	92%
3 month	90%
6 month	80%

Case Material ABS UL94 HB

Option: Flammability resistance of (UL94 V-0)

Terminal F1 or F2 (Faston Tab 187 or 250)



Dimensions

mm(inch)

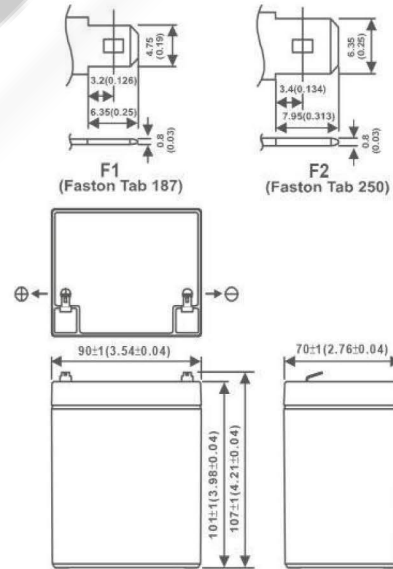

(V) FOR 12V BATTERY Discharge Time VS. Discharge Current (25°C)

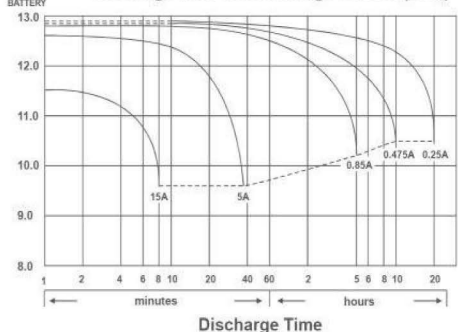

Effect of Temperature on Capacity 25°C (77°F)

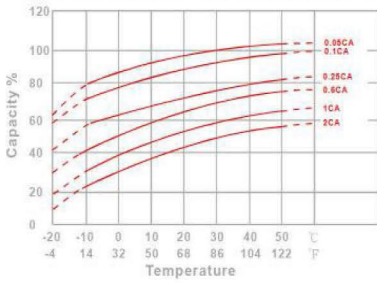

Capacity Retention Characteristic

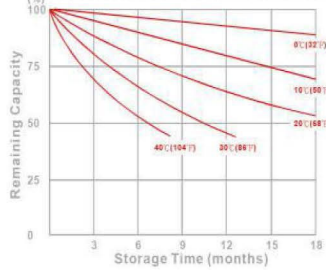

Trickle (or float) Service Life

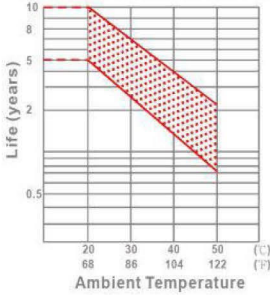

Cycle Service Life

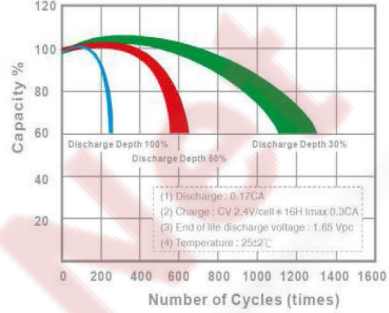

- PERFORMANCE DATA

Discharge Rates in Watts to Various End Voltages at 25°C (77°F)

Time	End Voltage	1.85V	1.80V	1.75V	1.70V	1.67V	1.65V	1.60V
5	min	36.3	39.5	41.5	43.5	44.3	45.5	47.0
10	min	25.7	27.7	29.2	30.2	30.7	31.3	32.3
15	min	19.7	21.2	21.8	22.5	22.8	23.2	23.7
30	min	11.2	11.7	12.1	12.5	12.7	12.8	12.9
60	min	5.95	6.27	6.47	6.70	6.82	6.93	7.07
120	min	3.13	3.38	3.53	3.65	3.72	3.80	3.92
180	min	2.53	2.72	2.85	2.97	3.02	3.07	3.15
240	min	2.02	2.15	2.27	2.33	2.37	2.40	2.45
300	min	1.73	1.87	1.95	1.98	2.00	2.02	2.05
600	min	1.01	1.09	1.15	1.17	1.18	1.19	1.21
1200	min	0.530	0.572	0.603	0.615	0.620	0.625	0.633

- Discharge Rates in Amperes to Various End Voltages at 25°C (77°F)

Time	End Voltage	1.85V	1.80V	1.75V	1.70V	1.67V	1.65V	1.60V
5	min	17.8	21.7	23.9	25.8	26.4	27.0	27.8
10	min	13.2	14.8	15.7	16.2	16.6	16.9	17.3
15	min	9.92	10.5	10.9	11.1	11.2	11.3	11.5
30	min	5.84	6.15	6.26	6.38	6.42	6.47	6.55
60	min	3.04	3.20	3.38	3.46	3.49	3.53	3.59
120	min	1.58	1.70	1.79	1.87	1.91	1.94	1.99
180	min	1.27	1.35	1.41	1.47	1.49	1.52	1.55
240	min	1.00	1.07	1.11	1.15	1.16	1.18	1.21
300	min	0.851	0.898	0.919	0.942	0.953	0.962	0.978
600	min	0.497	0.506	0.514	0.521	0.524	0.529	0.535
1200	min	0.268	0.274	0.279	0.284	0.286	0.287	0.291

All data on the spec. sheet is an average value:

The tolerance range : $X < 6\text{min}$ (+15%~-15%), $6\text{min} \leq X < 10\text{min}$ (+12%~-12%), $10\text{min} \leq X < 60\text{min}$ (+8%~-8%), $X \geq 60\text{min}$ (+5%~-5%)