

SK2-R Reader

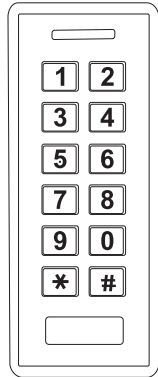

User Manual

1. Introduction

The SK2-R is a Wiegand output keypad, with integrated proximity reader. The keypad is of digital backlit, with built-in Light Dependent Resistor (LDR) sensor for anti-tamper. Because of waterproof, it can be mounted either indoor or outdoor in harsh environments.

3 versions available:

- SK2-R EM --- Read 125KHz EM Cards/Fobs
- SK2-R Mifare --- Read 13.56MHz Mifare Cards/Fobs
- SK2-R H&E --- Read 125KHz EM & HID Cards/Fobs

2. Specifications

Model	SK2-REM	SK2-R Mifare	SK2-RH&E
Frequency	125KHz	13.56MHz	125KHz
Card Type	EM Cards/Fobs	Mifare Cards/Fobs (ISO 14443A Compatible)	EM & HID Cards/Fobs
Read Range	4~8 cm	3~5 cm	4~8 cm
Standby Current	≤35mA	≤30mA	≤35mA
Operating Voltage	9~18V DC		
Wiegand Output Format	Wiegand 26 bits (factory default) 26~37 bits available upon request		
Keypad Transmission Format	4 bits (factory default) 8bits or virtual card number format are available upon request		
Operating Temperature	-40°C~60°C	-30°C~60°C	-40°C~60°C
Operating Humidity	0% RH ~ 96% RH		
Color	Black		
Index of Protection	IP66		
Dimension	L122 x W50 x D21 mm		
Net Weight	150g		
Shipment Weight	200g		

- 01 -

3. Installation

- Drill 2 holes (A, C) on the wall for the screws and one hole (B) for the cable
- Knock the rubber bungs to the holes (A, C)
- Fix the back cover on the wall with 2 screws
- Thread the cable through the cable hole (B)
- Attach the unit to the back cover

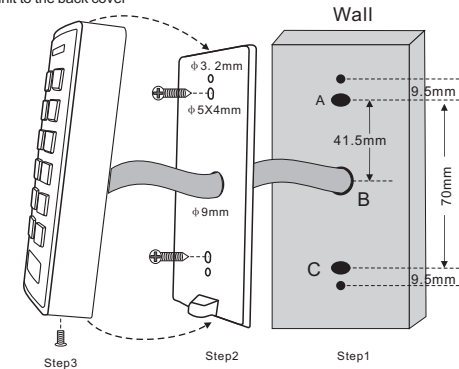

Wiring

Wire Color	Function	Notes
Red	Power +	+DC (9-18V DC)
Black	GND	Ground
Green	D0	Data 0
White	D1	Data 1
Brown	LED	Green LED Light Control
Yellow	Buzzer	Buzzer Control

(Remarks: Brown and Yellow wires are optional connections)

- 02 -

Connection Diagram

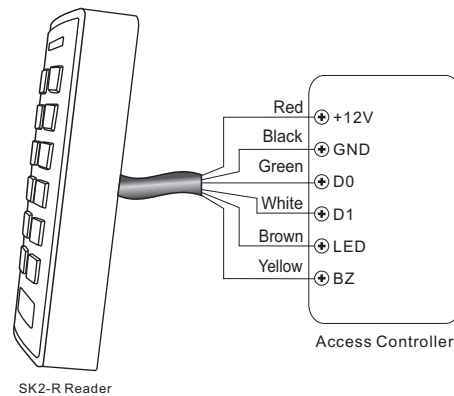

4. Function Table sheet

Read Card	The LED light will turn into Green, and the buzzer sounds a beep, at the meantime, the reader outputs the Wiegand signal
External LED Control	When the input voltage for LED is low, the LED will turn into Green
External Buzzer Control	When the input voltage for Buzzer is low, the Buzzer will sound
Wiegand Data Output	Wiegand 26~37 bits range available for SK2-R reader, factory default setting is Wiegand 26 bits. HID card can output Wiegand 26~37 automatically, EM and Mifare cards are forced to output based on the reader setting.

- 03 -

5. Data Signal

Pulse Times	
Description	SK2-R Typical Time
Pulse Width Time	42 μs
Pulse Interval Time	2 ms

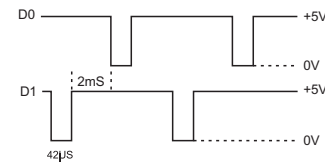

The above table shows the wave form of pulse width time (the duration of a pulse) and pulse interval time (the time between pulses) of the Wiegand data output from the readers. (Example 1010)

6. Keypad Transmission Format

The default keypad transmission format is 4bits. 8 bits or virtual card number format can be customized.

4 bits

The reader will transmit the PIN data after every key is pressed:

- 1 (0001), 2 (0010), 3 (0011)
- 4 (0100), 5 (0101), 6 (0110)
- 7 (0111), 8 (1000), 9 (1001)
- * (1010), 0 (0000), # (1011)

8 bits

The reader will transmit the PIN data after every key is pressed:

- 1 (1110 0001), 2 (1101 0010), 3 (1100 0011)
- 4 (1011 0100), 5 (1010 0101), 6 (1001 0110)
- 7 (1000 0111), 8 (0111 1000), 9 (0110 1001)
- * (0101 1010), 0 (1111 0000), # (0100 1011)

Virtual Card Number

The reader will transmit the PIN data when it receives the last key (#) after PIN code

Example: PIN code: 999999

Press 999999 #, then the output format will be: 0000999999

7. Packing List

Name	Quantity
Reader SK2-R	1
Manual	1
Screw Driver	1
Wall Fixing Plugs	2
Self Tapping Screws	2

- 04 -