

DIMENSIONS ARE IN MILLIMETERS

0.5-5 = +/- 0.2  
 5-30 = +/- 0.4  
 30-120 = +/- 0.6  
 120-315 = +/- 1  
 315-1000 = +/- 1.6  
 1000-2000 = +/- 2.4

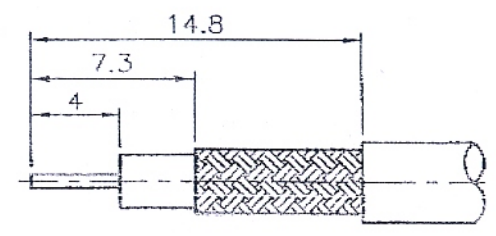
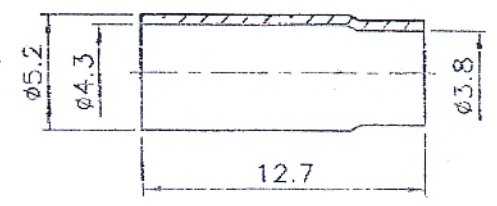
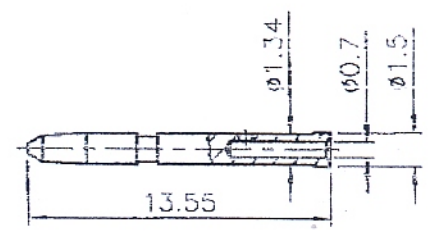
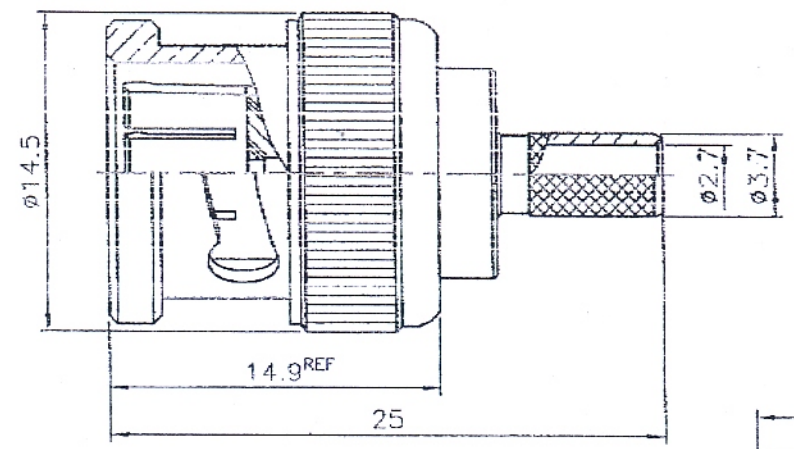

RECOMMENDED  
 CABLE STRIPPING DIM'S  
 (建議剝線尺寸)

1. CRIMPED FERRULE  
 HEX CRIMP SIZE .178" (4.52mm)  
 ( 套管壓着工具 )
2. CRIMPED CONTACT PIN  
 SQ. CRIMP SIZE .042" (1.06mm)  
 ( 中心針壓着工具 )

- NOTES: FINISH (PLATING THICKNESS IN MICRO-INCHES)
1. BRASS PER QQ-B-626
  2. NICKEL PL 70 MIN THICK OVER COPPER STRIKE
  3. COLD PL 3 MIN OVER NICKEL PL 70 MIN THICK OVER COPPER STRIKE
  4. BRASS JIS H 3250, C 2700
  5. TEFLON MIL-P-1946B

9	FERRULE	NOTE 4	NOTE 2
8	CONTACT PIN	NOTE 1	NOTE 3
7	SHELL	NOTE 1	NOTE 2
6	GASKET	SILICONE	RED
5	C RING	SS41	NOTE 2
4	SPRING	SK5	NOTE 2
3	WASHER	SS41	NOTE 2
2	INSULATOR	NOTE 5	WHITE
1	BODY	NOTE 1	NOTE 2

RoHS COMPLIANT

APPROVED BY :



**UNITED AU-VI CO., LTD.**

Description: BNC MALE CRIMP 75OHM

Part No.: V-7001Y/3727-0.7



NO.	DESCRIPTION	MATERIAL	FINISH	Q'TY	Date:
-----	-------------	----------	--------	------	-------

File No.: 7011NS700BF105B

JUL 20 2019