



GREY GREY Plus

DIGITAL DUAL TECHNOLOGY MOTION DETECTOR

grey_en 02/13

The GREY / GREY Plus detector allows detection of motion in the protected area.

1. Features

- Passive infrared (PIR) sensor and microwave sensor.
- Adjustable detection sensitivity of both sensors.
- Digital motion detection algorithm.
- Pet immunity up to 15 kg.
- Digital temperature compensation.
- Microwave based anti-mask feature [GREY Plus].
- Bi-color LED to indicate motion detection / alarm status.
- Remote LED enable/disable.
- Alarm memory.
- Capability of separate sensor testing.
- Supervision of detector signal path and supply voltage.
- Tamper protection against cover removal.

2. Specifications

Supply voltage	12 V DC ±15%
Standby current consumption	
GREY	10 mA
GREY Plus	13 mA
Maximum current consumption	
GREY	17 mA
GREY Plus	18 mA
Relay contacts rating (resistive load).....	40 mA / 16 V DC
Microwave frequency.....	24 GHz
Detectable speed.....	0.3...3 m/s
Alarm signaling period	2 s
Warm-up period	30 s
Recommended installation height	2.4 m
Environmental class according to EN50130-5	II
Operating temperature range	-10...+55 °C
Maximum humidity.....	93±3%
Dimensions	63 x 96 x 49 mm
Weight	
GREY	98 g
GREY Plus	100 g

The declaration of conformity may be consulted at www.satel.eu/ce

3. Description

The alarm will be triggered when both sensors detect motion within a time interval shorter than 5 seconds.

Anti-mask feature

Detection by the microwave sensor of an object moving at a distance of 10-20 centimeters from the detector is interpreted as an attempt to mask the detector and results in activation of anti-masking relay for two seconds. Objects permeable to microwaves, but isolating the infrared radiation are not detected by the anti-mask feature.

Supervision features

In the event of the voltage drop below 9 V ($\pm 5\%$) for more than 2 seconds or the signal path failure, the detector will signal a trouble. The trouble is indicated by the activation of alarm relay and the steady red light of LED indicator. The trouble signaling will continue as long as the trouble persists.

Remote LED enable/disable

The LED can be enabled/disabled remotely when the jumper is placed across the LED pins in OFF position. The LED terminal is provided to allow remote LED enable/disable. The LED is enabled, when the terminal is connected to the common ground, and disabled, when the terminal is disconnected from the common ground. You can connect to the LED terminal an OC type control panel output programmed e.g. as the SERVICE MODE STATUS, BI SWITCH or ZONE TEST STATUS.

Alarm memory

If the LED is enabled, the detector can signal the alarm memory. The MEM terminal is provided to allow the alarm memory enable/disable. The alarm memory is enabled, when the terminal is connected to the common ground. The alarm memory is disabled, when the terminal is disconnected from the common ground. If the alarm memory is enabled and an alarm occurs, the LED will start blinking red. Indication of the alarm memory will continue until the alarm memory is enabled again (the MEM terminal is connected to the common ground). Disabling the alarm memory will not stop the alarm memory indication. You can connect to the MEM terminal an OC type control panel output programmed e.g. as the ARMED STATUS.

4. Electronics board

① microwave sensor.

② terminals:

- NC** - alarm output (NC relay);
- TMP** - tamper output (NC);
- AM** - anti-masking output (NC relay) [GREY Plus];
- MEM** - alarm memory control;
- LED** - remote LED control;
- COM** - common ground;
- 12V** - power input.

③ bi-color LED to indicate:

- alarm – the LED lights red for 2 seconds;
- alarm memory – the LED is blinking red;
- motion detected by one of the sensors – the LED lights green for 2 seconds;
- trouble – the LED lights red;
- warm-up – the LED is blinking alternately red and green.

④ dual element pyrosensor. **Do not touch the pyroelectric sensor, so as not to soil it.**

⑤ tamper switch.

⑥ detector configuration pins:

- PET** - enable/disable the pet immunity option. The option is enabled when the jumper is set in ON position (Fig. 2).
- LED** - enable/disable the LED indicator. The LED is enabled, when the jumper is set in ON position (Fig. 2) – the remote LED enable/disable is not available then.

⑦ fixing screw hole.

⑧ potentiometer for adjustment of PIR sensor sensitivity.

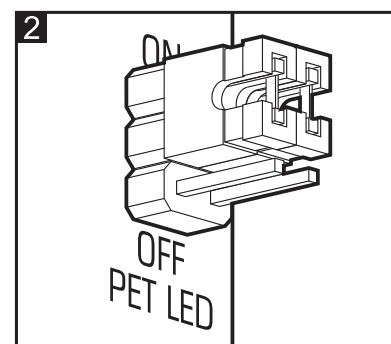
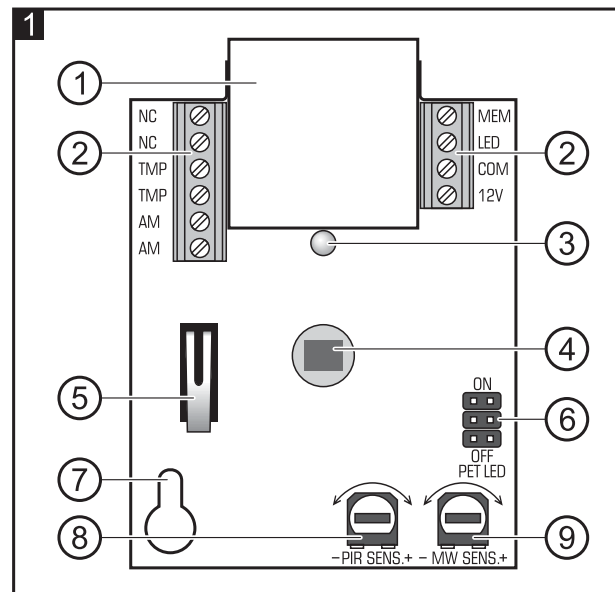

- ⑨ potentiometer for adjustment of the microwave sensor sensitivity. Please bear in mind that microwaves can penetrate e.g. glass, gypsum walls, non-metallic doors, etc.

5. Installation



Disconnect power before making any electrical connections.

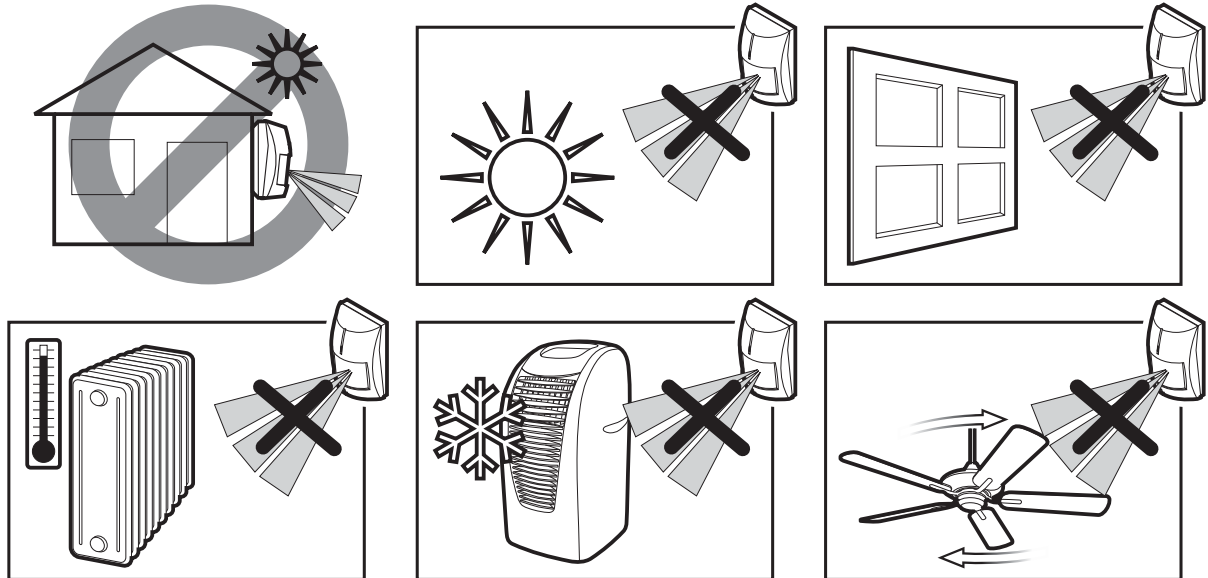

1. Remove the front cover (Fig. 3).
2. Remove the electronics board.
3. Make the openings for screws and cable in the enclosure base.
4. Pass the cable through the prepared opening.
5. Secure the enclosure base directly to the wall or to the bracket screwed down to the wall/ceiling (Fig. 4 and 5). The detector must not be mounted on the bracket, if the pet immunity option is to be enabled.

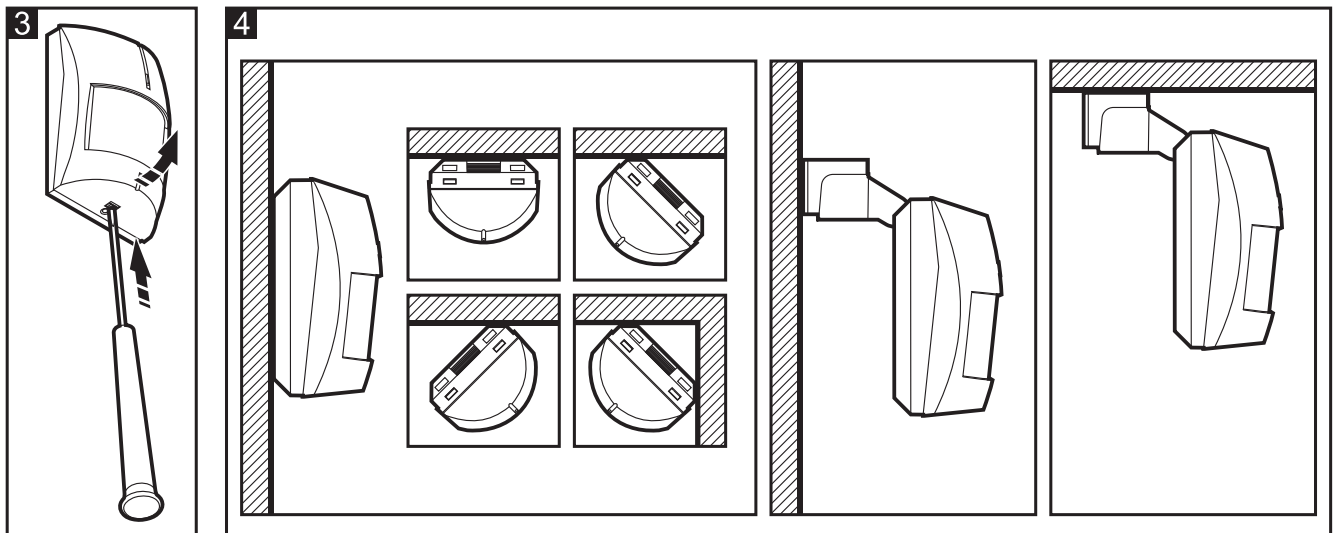

6. Fasten the electronics board.
7. Connect the wires to the corresponding terminals.
8. Using potentiometers and jumpers, set the detector working parameters.
9. Replace the cover.

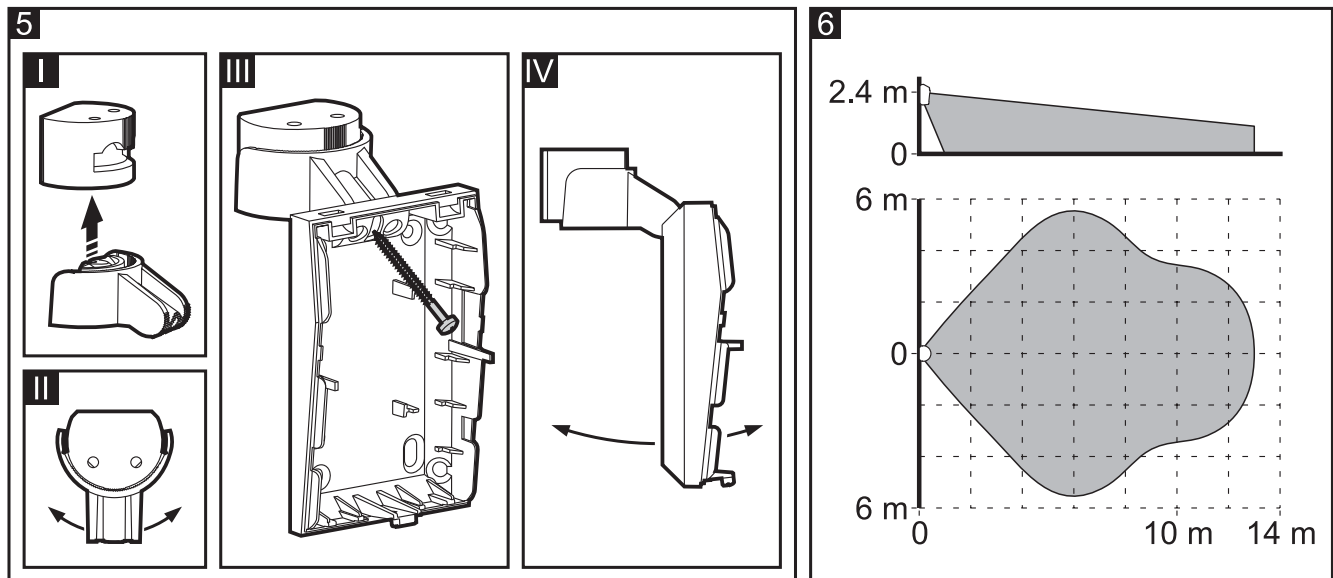

6. Start-up and walk test

Note: When testing the detector, the LED should be enabled.

1. Power-up the detector. The LED will begin alternately blinking red and green, which indicates the detector warm-up.
2. When the LED stops blinking, check that moving within the coverage area (Fig. 6 shows the maximum coverage area – at the maximum sensitivity and the jumper placed across PET pins in OFF position) will activate the alarm relay and make the LED light up red.

Separate testing of sensors

To test the microwave sensor, do the following:

1. Before you power-up the detector, place the jumper across the PET pins in the ON position.
2. Power-up the detector and, during the warm-up period, remove the jumper from PET pins and set it to OFF position. After completion of the warm-up, the LED should flash green every 3 seconds.
3. Check that moving within the coverage area will activate the alarm relay and make the LED light up green.

To test the PIR sensor, do the following:

1. Before you power-up the detector, place the jumper across the PET pins in the OFF position.
2. Power-up the detector and, during the warm-up period, remove the jumper from PET pins and set it to ON position. After completion of the warm-up, the LED should flash red every 3 seconds.
3. Check that moving within the coverage area will activate the alarm relay and make the LED light up red.

Note: The sensor separate testing mode is automatically exited after 20 minutes.