

- NOTES:
1. MATERIAL:  
 TERMINAL: COPPER ALLOY  
 SHELL: COPPER ALLOY  
 HOUSING: THERMOPLASTIC, UL94 V-0;
  2. PLATING: SEE PART NUMBER CODE;
  3. DATUM AND BASIC DIMENSIONS ESTABLISHED BY CUTOMER;
  4. RECOMMENDED PCB THICKNESS IS 1.57MM;
  5. 2.67MM MAXIMUM PANEL THICKNESS IF MOUNTED BEHIND PANEL;
  6. PRODUCT SPECIFICATION: GS-12-095;
  7. PACKAGE SPECIFICATION: GS-14-393;
  8. COMPLIED WITH USB 2.0 AND TID NUMBER 60000205;
  9. 87583-3010XXX DURABILITY MEET 9,000 CYCLES,  
 AND THE OTHER PART MEET USB 2.0 1,500 CYCLES;  
 (TO BE CONTINUED ON PAGE 3)

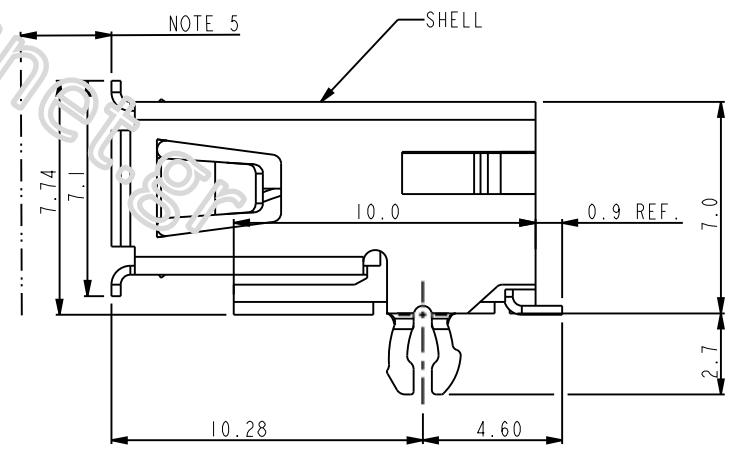
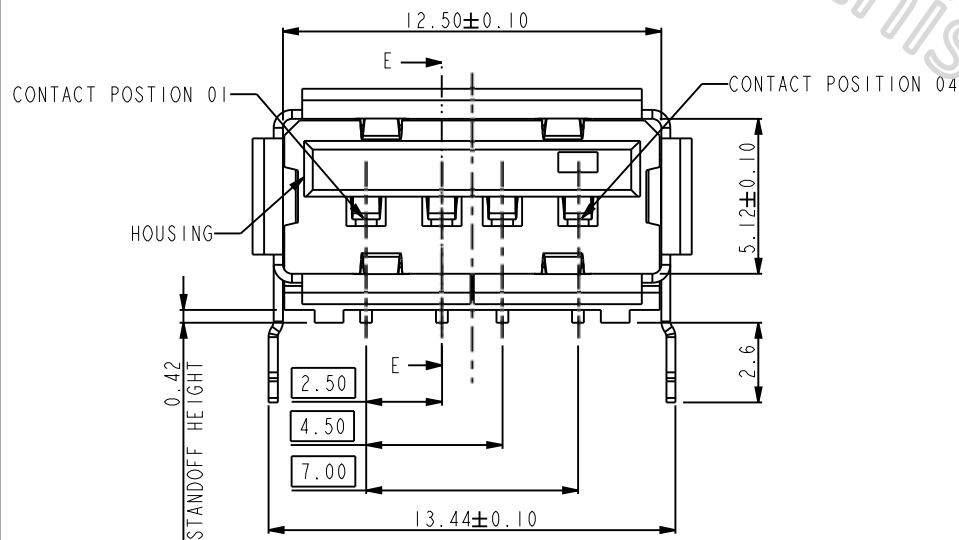

Copyright FCI.

rev	ecn no	dr	date
W	N07-0304	R.B	12/31/2007
X	N08-0162	R.B	08/06/2008
Y	N08-0238	R.B	11/03/2008
AA	N09-0356	R.B	11/05/2009
AB	N10-0260	K.W	08/17/2010
V	N07-0050	WG	02/13/2007

www.fciconnect.com		surface <input checked="" type="checkbox"/>	tolerance std	projection	MM
		TOLERANCES UNLESS OTHERWISE SPECIFIED			
Dr	PETER	3/18/98	ANGULAR	size	Scale
Eng	R Y LIU	3/18/98	LINEAR	A4	4.000
Chr	R Y LIU	3/18/98	0° ±2°	ECN	N10-0260
Appr	JENN TSAO	3/18/98	Product family	Spec ref	
		title UNIV. SERIAL BUS S.M. RECEPTACLE		dwg no	87583
		catalog no		CUSTOMER	Rev. AB
				sheet 1 of 3	

REV F - 2006-04-11



Copyright FCI.

A  
B  
C  
D

1 2 3 4

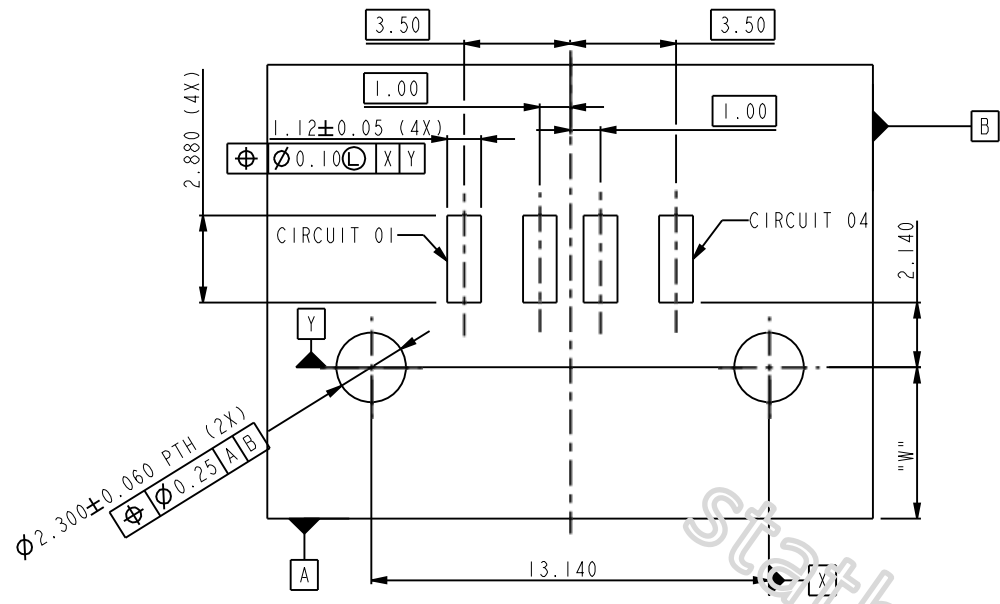

RECOMMENDED PCB LAYOUT  
COMPONENT SIDE  
TOLERANCE: ±0.05

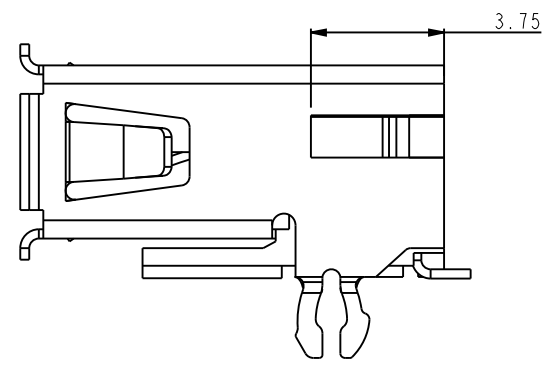

MEET DURABILITY 1,500 CYCLES P/N: 87583-2010XXX

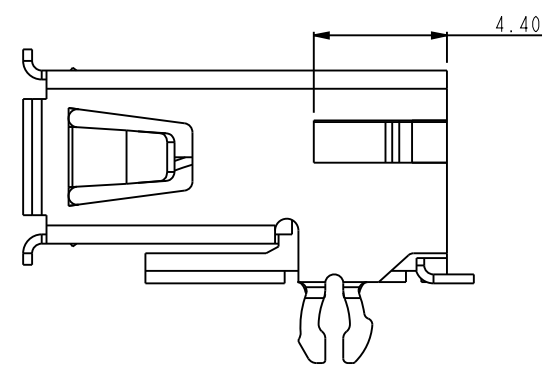

MEET DURABILITY 9,000 CYCLES P/N: 87583-3010XXX

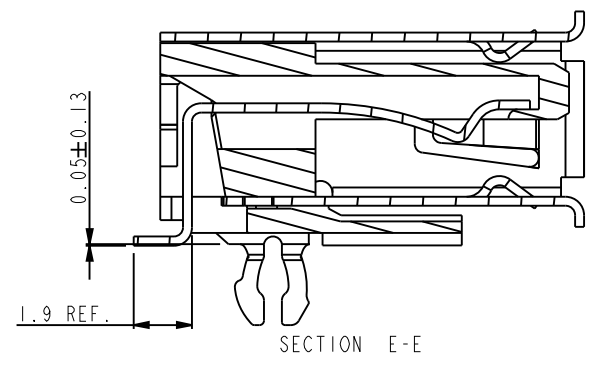

www.fciconnect.com			surface	✓	tolerance std	projection	MM					
			TOLERANCES UNLESS OTHERWISE SPECIFIED				⊕	↔				
Dr	PETER	3/18/98	ANGULAR	LINEAR	0.X	±0.30	size	A4	Scale	4.000		
Eng	R Y LIU	3/18/98			0.XX	±0.20			ECN	N10-0260		
Chr	R Y LIU	3/18/98			0°	±2°	0.XXX	±0.10	Spec ref			
Appr	JENN TSAO	3/18/98	Product family									
FCI			title			UNIV. SERIAL BUS S.M.		dwg no		87583	Rev.	AB
			RECEPTACLE					CUSTOMER		sheet 2 of 3		
			catalog no									

# PRODUCT NUMBER CODE

87583 - X X X X X P X LF

BASE PRODUCT NUMBER

HOUSING COLOR OPTIONS

- 0- WHITE+TIN OVER NICKLE UNDERPLATE
- 1- BLACK+TIN OVER NICKLE UNDERPLATE
- 2 - WHITE+SHELL Ni PLATING ONLY
- 3 - BLACK+SHELL Ni PLATING ONLY
- S - BLACK+SHELL Ni PLATING ONLY (SPECIAL MATERIAL FOR 12,000 DURABILITY CYCLES)

SHELL OPTION

- 0 - NO BACK SHIELD

MOUNTING HOLE OPTIONS

- 1 - NONE

TERMINAL PLATING OPTION

- 0 - 50u" Ni UNDERPLATE
- 30u" GXT CONTACT AREA
- 100u" TIN TAIL AREA

PACKAGING OPTIONS

- B - TUBES
- R - TAPE & REEL

DATE CODE

- A FOR AUTOMOTIVE APPLICATION
- H FOR HPQ SMT

LEAD FREE OPTION

## AVAILABLE P/N LIST

87583-0010BHLF	
87583-0010BLF	OB
87583-0010RLF	OB
87583-1010BLF	OB
87583-1010RPALF	
87583-1010RPLF	OB
87583-2010BLF	
87583-2010BPLF	
87583-2010RLF	
87583-2010RPLF	
87583-3010BLF	
87583-3010BPLF	
87583-3010RPALF	
87583-3010RPLF	
87583-S010XPFL	

stathisnet.gr

(CONTINUE)

- 9. P/N'S WITH SUFFIX "LF" ARE LEAD FREE P/N'S
- 10. FOR LEAD FREE P/N, THE PRODUCT MEET EUROPEAN UNION DIRECTIVES AND OTHER COUNTRY REGULATION AS DESCRIBED IN GS-22-008
- 11. THE HOUSING WILL WITHSTAND EXPOSURE TO 260°C PEAK TEMPERATURE FOR 40 SECONDS IN A CONVECTION, INFRO-RED OR VAPOR PHASE REFLOW OVEN.
- 12. FOR AUTOMOTIVE APPLICATION: ALL THE TOLERANCES ".XX" ARE ±0.10 UNLESS OTHER SPECIAL NOTIFICATION

www.fciconnect.com			surface <input checked="" type="checkbox"/>	tolerance std	projection	MM						
			TOLERANCES UNLESS OTHERWISE SPECIFIED									
Dr	PETER	3/18/98	ANGULAR	LINEAR	0.X	±0.30	size	A4	Scale	4.000		
Eng	R Y LIU	3/18/98			0.XX	±0.20	ECN	N10-0260				
Chr	R Y LIU	3/18/98	0°	±2°	0.XXX	±0.10						
Appr	JENN TSAO	3/18/98	Product family				Spec ref					
		title			UNIV. SERIAL BUS S.M.		dwg no		87583		Rev.	AB
		catalog no			CUSTOMER		sheet 3 of 3					