

**iroda**

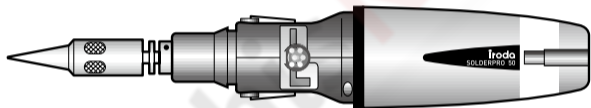

**SOLDERPRO™ 50K**  
Pocket Sized Butane Soldering Iron Kit

**Instruction Manual**  
READ INSTRUCTIONS AND WARNINGS BEFORE USE

## IMPORTANT SAFETY INSTRUCTIONS

### Warnings:

- Unit uses flammable gas (Butane) under pressure – use with care.
  - DO NOT expose to heat above +50°C (120°F) and avoid prolonged exposure to the sun.
  - DO NOT puncture or incinerate.
  - DO NOT refill, ignite or use near open flame, heater, furnace or combustible materials.
  - Keep work area clean. Cluttered areas and benches invite injuries.
  - KEEP AWAY FROM CHILDREN. Visitors should be kept away from work area.
  - Store in dry, locked cabinet out of reach of children.
- Be extremely careful as torch flame tip temperature is over 1300°C (2400°F)
  - Be extremely careful as torch flame is almost invisible in daylight or under strong light.
  - Use Safety Glasses.
  - Do not touch the heated tip of the unit.
  - DO NOT leave unit unattended when operating or hot.
  - Always be sure unit is cool before storing.
  - DO NOT replace cap without switching unit off and ensuring tip has cooled.
  - If your torch malfunctions do not try to repair. Contact your dealer or online support for help.
  - Butane-Propane mix or other fuel could create much higher temperatures and cause flare-up at the tip exhaust slots.

## DESCRIPTION

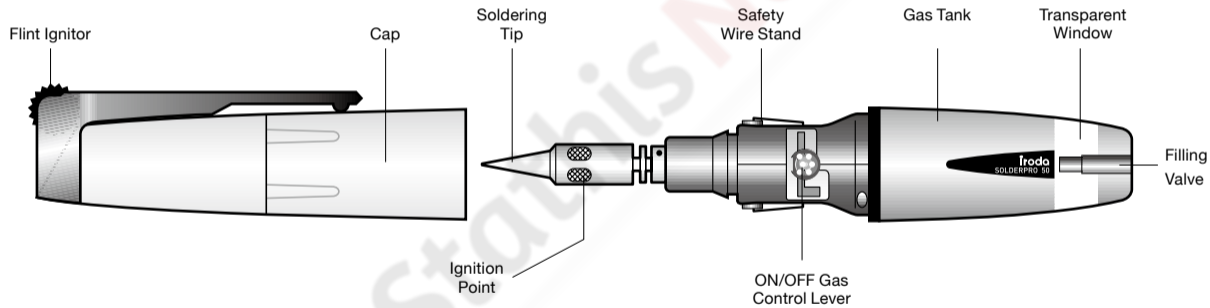

## HOW TO USE THE SOLDERPRO 50K

### REFILLING

Fig.1

- Use only high-quality butane gas.
  - Refill in a well-ventilated area away from any ignition source and other people.
1. Hold butane canister upside down when filling (Fig.1)
  2. Firmly press canister nozzle into **Gas Filling Valve**.
  3. Release canister when gas starts to overflow.  
(Gas overflow during refilling is normal and does not indicate a leak)
  4. Wait for a few minutes before use.



Fig.1

### IGNITION

1. Push the **ON/OFF lever** upward and to the right, and set to **mid** position. (Fig. 2)
2. Ignite the gas stream with the **Flint Ignitor** located on the Torch Cap. (Fig. 3a Fig. 3b) (You can also use a regular lighter.) The tip will flame for a few seconds and then the catalyst will change to an orange glow.

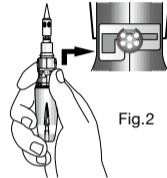

Fig.2

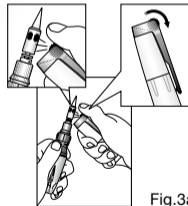

Fig.3a

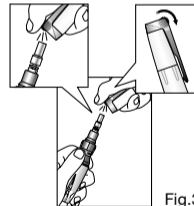

Fig.3b

## IGNITION WARNINGS

- Do not touch Tip, Tip Housing or Knurled Nut while igniting. (Fig. 4)
- Do not ignite torch when Tip Assembly is not screwed on. (Fig. 5)

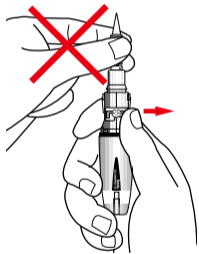

Fig.4

8

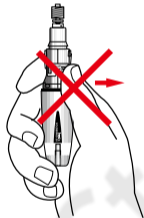

Fig.5

## TEMPERATURE ADJUSTMENT

- The tip temperature can be adjusted by turning the **ON/OFF Gas Control Lever** left or right. (Fig. 6)
- Set to mid-position when soldering or brazing.
- Excessive gas flow, flare-up or catalyst pulsing red may occur when the **Gas Control Lever** is set too high.

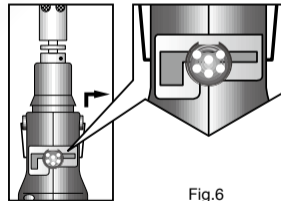

Fig.6

9

## CHANGING TIPS

1. Be sure the tip has cooled before removal.
2. Unscrew tip with a counterclockwise motion. (Fig. 7) Pliers may be required to lightly grasp the tip in order to loosen it.
3. Replace with desired tip. Be careful not to overtighten as this could damage the thread in the cap.

**WARNING:** The catalyst inside the soldering tip is very delicate and will not sustain mechanical abuse without serious damage.

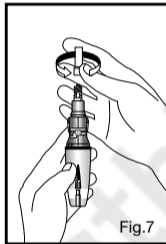

## CLEANING

- Use only mild soap and a damp cloth to clean the housings of the tool. Many household cleaners contain chemicals which could seriously damage the plastic. Also do not use gasoline, turpentine, lacquer or paint thinner, dry cleaning fluids or similar products. Never let any liquid get inside the tool; never immerse any part of the tool into a liquid.

## TROUBLE SHOOTING

- To reduce the risk of personal injury, property damage, or damage to your SOLDERPRO 50, do not attempt to repair the unit body.

PROBLEM	PROBABLE CAUSE	HOW TO CORRECT
Does not ignite	a. Empty Gas Tank b. Too high or low fuel pressure c. Pushing on/off ignition switch too fast.	a. Refill with butane fuel b. Adjust control lever to a higher or lower position. c. Re-read IGNITION steps
Low gas pressure or low flame	a. Cold fuel b. Low fuel	a. Hold body in hands to allow unit to warm up. b. Refuel
Tip does not heat up	a. Used-up catalyst b. Insufficient fuel pressure	a. Replace with new tip. b. Adjust control lever to a higher position.

## SPECIAL WARNING

- This product, when used for soldering and similar applications, produces chemicals known to the State of California to cause cancer and birth defects or other reproductive harm.
- Department of Transportation Hazardous Materials Regulations forbid the carriage of butane or other flammable gas products on passenger aircraft. Do not pack this item or any other flammable gas item, in any checked or carry-on baggage.

## SPECIFICATIONS

Length	W / Cap	155 mm (6.1 inches)
	W / Soldering Tip	140 mm (5.5 inches)
Height		28 mm (1.1 inches)
Weight	Empty Fuel Tank	56 g ± 2 g
Watt		30 W - 70 W
BTU		346.5
Approximate Temperature	Soldering Tip	≈ 842 °F (450 °C)
	Torch	≈ 2400 °F (1300 °C)
	Hot Knife	≈ 842 °F (450 °C)
	Heat Blower	≈ 1300 °F (650 °C)
Capacity	Gas Container	7 ml (0.24 oz)
Flame Length	Mid Setting	1 cm (0.4 inches)
Operating Time	Mid Setting / One Gas Filling	40 min.
Heat Up Time	Working Temperature	18 seconds

This appliance may be filled with any cartridges marked "Butane" complying with EN 417.

**Warning:**

- Use outdoors only or use in well ventilated areas.
- Read the instructions before using the appliance.

**CAUTION:**

- Accessible parts may be very hot. Keep young children away from the appliance.



StatHisNet

**iroda**

[www.pro-iroda.com](http://www.pro-iroda.com)