

Data sheet: Short Circuit Proof Safety Isolating Transformers Type AVB

Description.....: Safety isolating transformer constructed and tested according to VDE 0570/EN 61 558, UL 506, CSA 22.2

Approvals: According to table

Test voltage..... PRI - SEC 5000 V, 50 Hz

Short-circuit protection: Inherently short-circuit proof

Construction.....: Open design, potted in insulation housing

Safety class: Prepared for class II equipment

Protection index: Connections IP 00
Housing IP 65

Max ambient temperature: According to table

Insulation class of the insulation system.....: VDE (B= 130°C) ; UL+CSA Class 105 (A=105°C)

Input voltage: 2 x 115V

Frequency.....: 50 - 60 Hz

Output voltage.....: According to table

Connections: Soldering pins for printed circuit board mounting

Packing.....: Separately packed in cartons

Schematic plan :

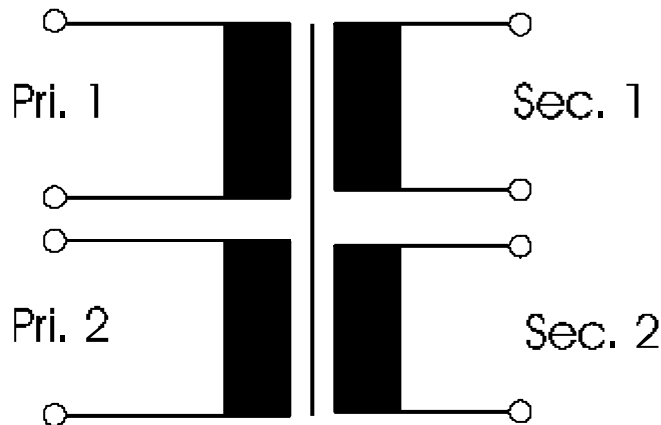

Description :

These AVB type resin moulded safety isolating transformers, are inherently short-circuit proof so do not require external protection. The dual input and output windings are for series or parallel connection.

Note :

- * vacuum epoxy resin moulded (self-extinguishing to UL 94 V0)
- * 100% tested
- * Two chamber bobbin construction

Output power 0,35 VA Core-type EE 20/6,1
 Height 15,0 mm Weight 24g
 Ground area 22 mm x 22,7 mm

Type	SEC rated output-		Approvals
	voltage V	current A	
AVB 0,35/2/6	2x6	2x0,029	1
AVB 0,35/2/8	2x8	2x0,021	1
AVB 0,35/2/9	2x9	2x0,019	1
AVB 0,35/2/12	2x12	2x0,014	1
AVB 0,35/2/15*	2x15	2x0,011	1
AVB 0,35/2/18*	2x18	2x0,009	1
AVB 0,35/2/24*	2x24	2x0,007	1

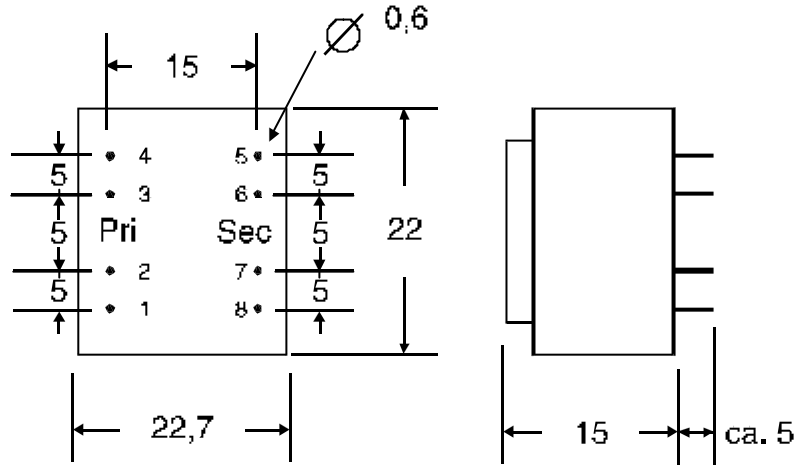

according to VDE 0570/EN 61 558 -1 : 1997 with part 2-6

* = according to VDE 0570/EN 61 558 -1 : 1997 with part 2-1

Pinning:

Input: 2 x 115V..... (1-2) and (3-4)

Output (5-6) and (7-8)

No load output voltage x Factor = typ. 1,8
 Core Losses typ. 1,3 W
 Efficiency typ. 30 %
 Ambient Temperature (ta) +70°C



Output power 0,5 VA Core-type EE 20/10,5

Height 19,0 mm Weight 35g

Ground area 22 mm x 22,7 mm

Type	SEC rated output-voltage V	current A	Approvals
AVB 0,5/2/6	2x6	2x0,041	1
AVB 0,5/2/8	2x8	2x0,031	1
AVB 0,5/2/9	2x9	2x0,027	1
AVB 0,5/2/12	2x12	2x0,020	1
AVB 0,5/2/15*	2x15	2x0,016	1
AVB 0,5/2/18*	2x18	2x0,013	1
AVB 0,5/2/24*	2x24	2x0,010	1

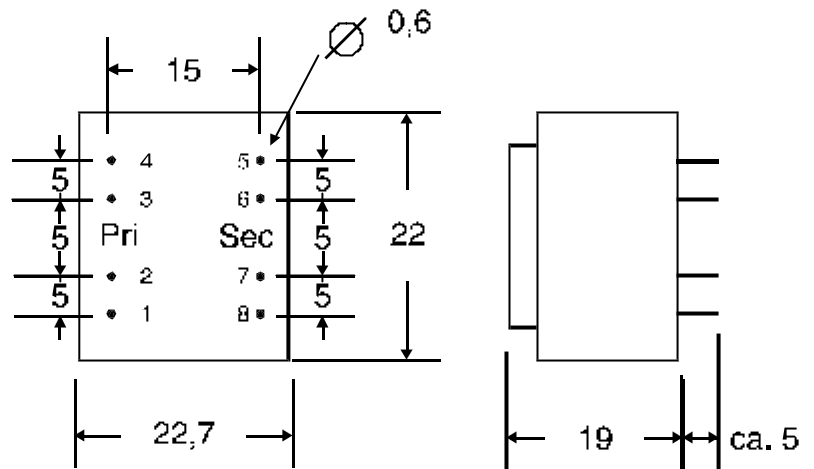

according to VDE 0570/EN 61 558 -1 : 1997 with part 2-6

* = according to VDE 0570/EN 61 558 -1 : 1997 with part 2-1

Pinning:

Input: 2 x 115V..... (1-2) and (3-4)

Output (5-6) and (7-8)

No load output voltage x Factor = typ. 1,8

Core Losses typ. 0,8 W

Efficiency typ. 40 %

Ambient Temperature (ta) +70°C

Approvals



Output power 1,0 VA Core-type EI 30/10,5

Height 21,8 mm Weight 72g

Ground area 32,3 mm x 27,3 mm

Type	SEC rated output-		Approvals
	voltage V	current A	
AVB 1,0/2/6	2x6	2x0,083	1
AVB 1,0/2/8	2x8	2x0,062	1
AVB 1,0/2/9	2x9	2x0,055	1
AVB 1,0/2/12	2x12	2x0,041	1
AVB 1,0/2/15	2x15	2x0,033	1
AVB 1,0/2/18*	2x18	2x0,027	1
AVB 1,0/2/24*	2x24	2x0,020	1

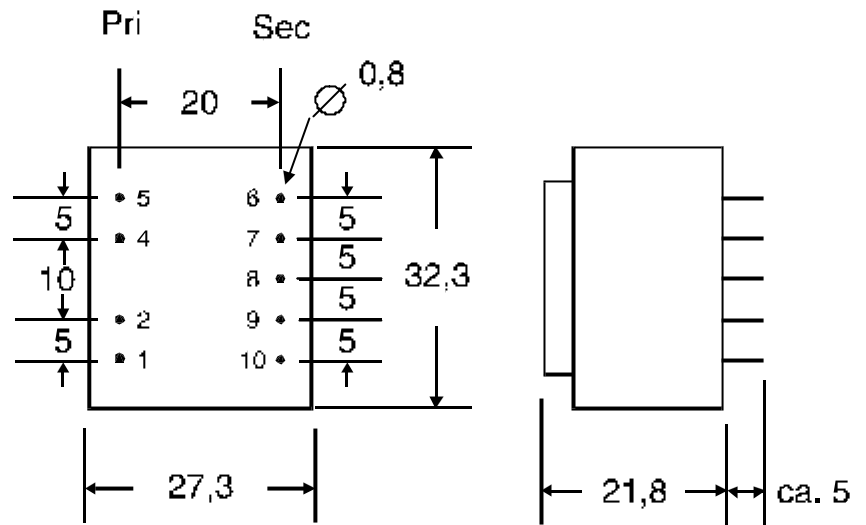

according to VDE 0570/EN 61 558 -1 : 1997 with part 2-6

* according to VDE 0570/EN 61 558 -1 : 1997 with part 2-1

Pinning:

Input: 2 x 115V..... (1-2) and (4-5)

Output (10-9) and (7-6) pin 8 fitted but not connected.

No load output voltage x Factor = typ. 1,32
 Core Losses typ. 0,6 W
 Efficiency typ. 55 %
 Ambient Temperature (ta) +70°C

Approvals  (1)

Output power 1,5 VA Core-type EI 30/12,5

Height 23,8 mm Weight 84g

Ground area 32,3 mm x 27,3 mm

Type	SEC rated output-		Approvals
	voltage V	current A	
AVB 1,5/2/6	2x6	2x0,125	1
AVB 1,5/2/8	2x8	2x0,093	1
AVB 1,5/2/9	2x9	2x0,083	1
AVB 1,5/2/12	2x12	2x0,062	1
AVB 1,5/2/15	2x15	2x0,050	1
AVB 1,5/2/18*	2x18	2x0,041	1
AVB 1,5/2/24*	2x24	2x0,031	1

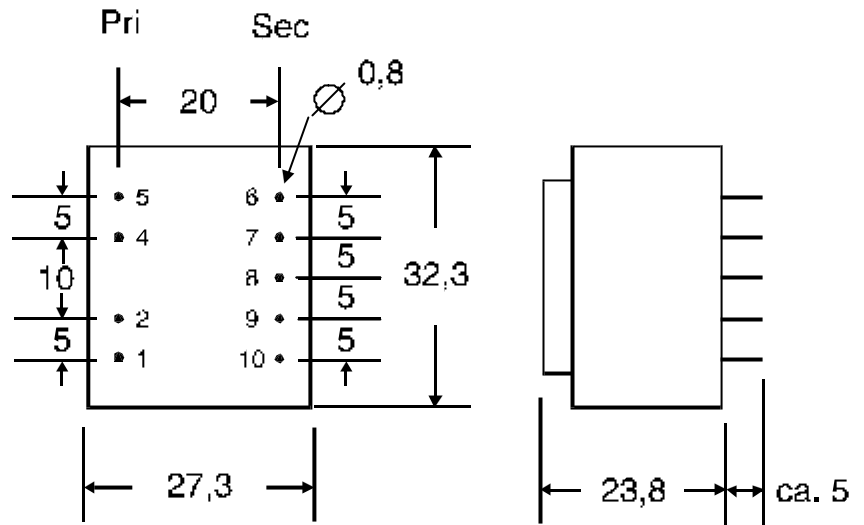

according to VDE 0570/EN 61 558 -1 : 1997 with part 2-6

*according to VDE 0570/EN 61 558 -1 : 1997 with part 2-1

Pinning:

Input: 2 x 115V..... (1-2) and (4-5)

Output (10-9) and (7-6) pin 8 fitted but not connected.

No load output voltage x Factor = typ. 1,39
 Core Losses typ. 0,6 W
 Efficiency typ. 57 %
 Ambient Temperature (ta) +70°C



Output power 2,3 VA Core-type EI 30/18

Height 29 mm Weight 110g

Ground area 32,3 mm x 27,3 mm

Type	SEC rated output-		Approvals
	voltage V	current A	
AVB 2,3/2/6	2x6	2x0,191	1
AVB 2,3/2/8	2x8	2x0,143	1
AVB 2,3/2/9	2x9	2x0,127	1
AVB 2,3/2/12	2x12	2x0,095	1
AVB 2,3/2/15	2x15	2x0,076	1
AVB 2,3/2/18*	2x18	2x0,063	1
AVB 2,3/2/24*	2x24	2x0,047	1

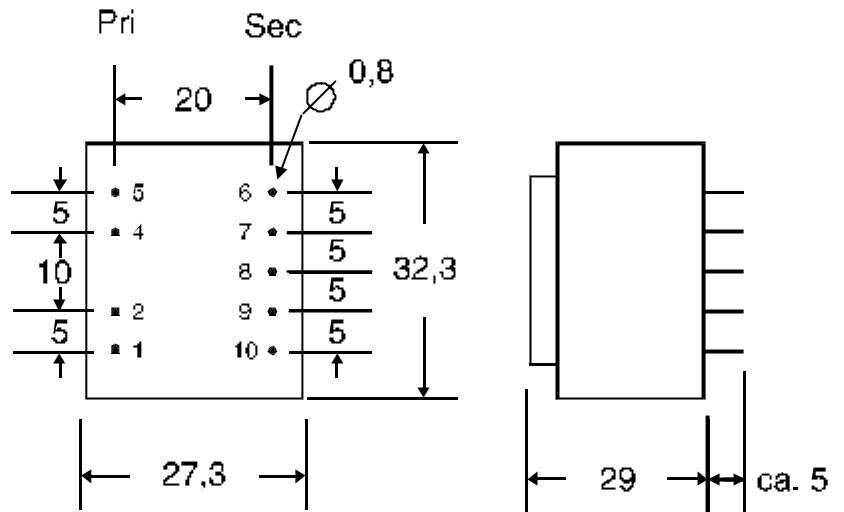

according to VDE 0570/EN 61 558 -1 : 1997 with part 2-6

*according to VDE 0570/EN 61 558 -1 : 1997 with part 2-1

Pinning:

Input: 2 x 115V..... (1-2) and (4-5)

Output (10-9) and (7-6) pin 8 fitted but not connected.

No load output voltage x Factor = typ. 1,43
 Core Losses typ. 0,6 W
 Efficiency typ. 59 %
 Ambient Temperature (ta) +70°C



Output power 3,2 VA Core-type EI 38/16,5
 Height 30,8 mm Weight 173g
 Ground area 41 mm x 35 mm

Type	SEC rated output-		Approvals
	voltage V	current A	
AVB 3,2/2/6	2x6	2x0,266	1
AVB 3,2/2/8	2x8	2x0,20	1
AVB 3,2/2/9	2x9	2x0,177	1
AVB 3,2/2/12	2x12	2x0,133	1
AVB 3,2/2/15	2x15	2x0,106	1
AVB 3,2/2/18*	2x18	2x0,088	1
AVB 3,2/2/24*	2x24	2x0,066	1

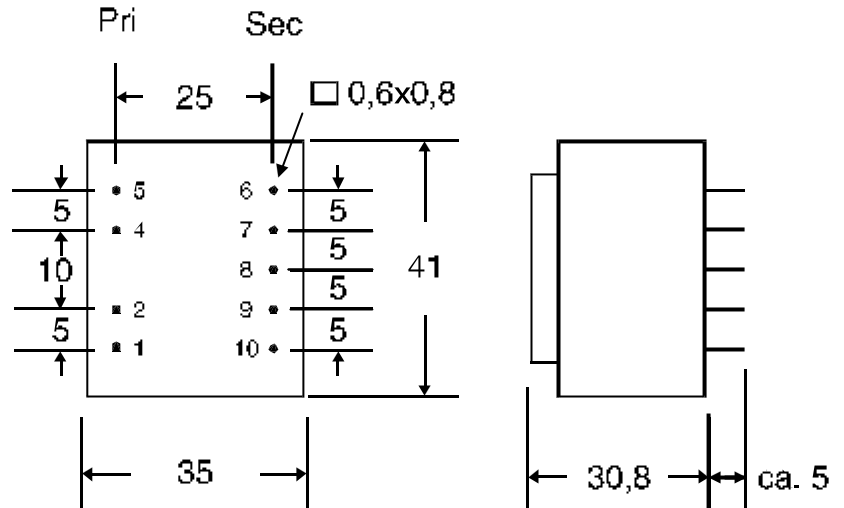

according to VDE 0570/EN 61 558 -1 : 1997 with part 2-6
 *according to VDE 0570/EN 61 558 -1 : 1997 with part 2-1

Pinning:

Input: 2 x 115V..... (1-2) and (4-5)
 Output (10-9) and (7-6) pin 8 fitted but not connected.

No load output voltage x Factor = typ. 1,57
 Core Losses typ. 0,47 W
 Efficiency typ. 58 %
 Ambient Temperature (ta) +50°C

